

AVAILABLE BY SPECIAL ORDER ONLY

PART NO.	DIM. "A"±0.4
LCBS-6M-01	6
LCBS-8M-01	8
LCBS-10M-01	10
LCBS-12M-01	12
LCBS-14M-01	14
LCBS-16M-01	16

TO SNAP-LOCK IN A 4±0.08 DIA. HOLE, IN A 1.57 THICK BOARD

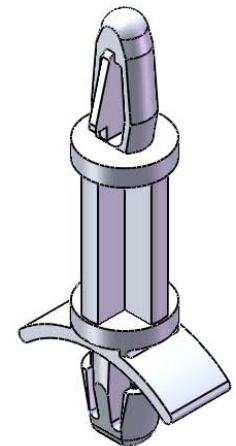
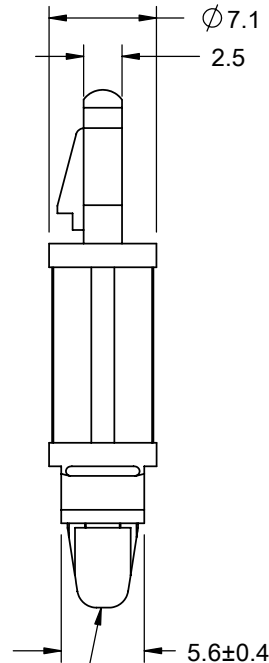
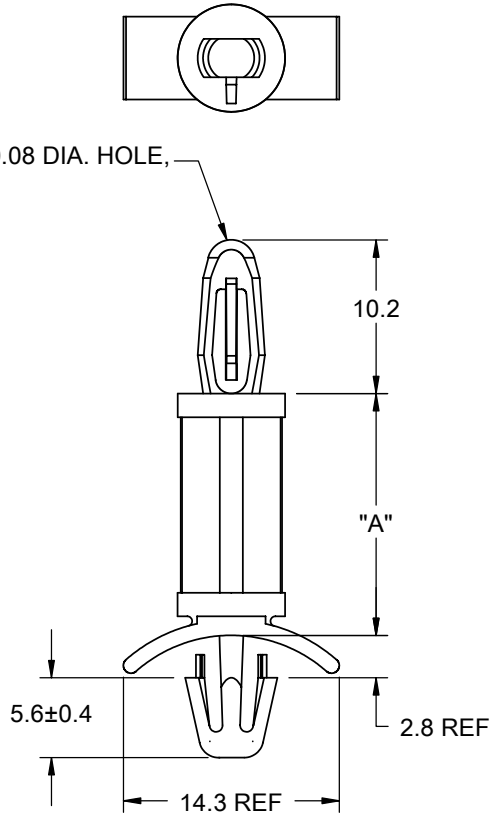

NOTES:

- MATERIAL: NYLON 6/6 UL 94 V-2 (RMS-01).
MATERIAL: NYLON 6/6 UL 94 V-0 (RMS-19),
AVAILABLE BY SPECIAL ORDER. TO ORDER
REPLACE "-01" WITH "-19".
- COLOR: BLUE.

TITLE: LOCKING CIRCUIT BOARD SUPPORT (METRIC)				DWG IN mm		FINAL	
CREATED USING SOLIDWORKS		FILE #: LCBS-M	DWN: SK	APP: RT		PART #	
GENERAL TOLERANCE UNLESS NOTED		SHEET: 1 OF 1	SHEET SIZE: A	DT: 11/16/06	CHKD: SJ	PRINT TYPE	
±0.25 ANG.±1°		RE: RICHCO, INC.		RICHCO, INC. ENG@RICHCO-INC.COM (773) 539-4060		SEE TABLE CA	

D	DESCRIPTION	SK	DATE
-	REDRAWN, SEE ECN #1208 FOR CHANGES	SK	11/29/06
REV.	SEE ENGINEERING FOR REV A-C	ENGR.	DATE